

PARTS LIST

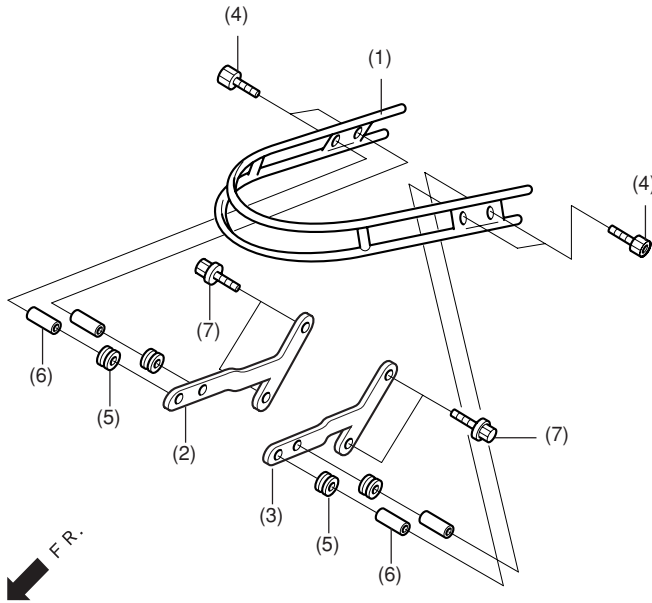

No.	Description	Q'ty
(1)	Front fender rail	1
(2)	Right stay	1
(3)	Left stay	1
(4)	6 mm Socket bolt	4
(5)	Grommet	4
(6)	Collar	4
(7)	6 mm Flange bolt	4

TOOLS AND SUPPLY REQUIRED

- Socket (8 mm)
- Ratchet
- Hex wrench (5 mm)
- Box-end wrench (10 mm)
- Electric drill motor
- Drill bit (3mm,6mm,9mm and 14 mm)
- Wood block
- Torque wrench

TORQUE CHART

Be sure to tighten all bolts to their specified torques.

Item	N·m	kgf·m	lbf·ft
6mm Socket bolt	10	1.0	7
6mm Flange bolt	12	1.2	9

INSTALLATION

- Remove the front fender from the motorcycle.

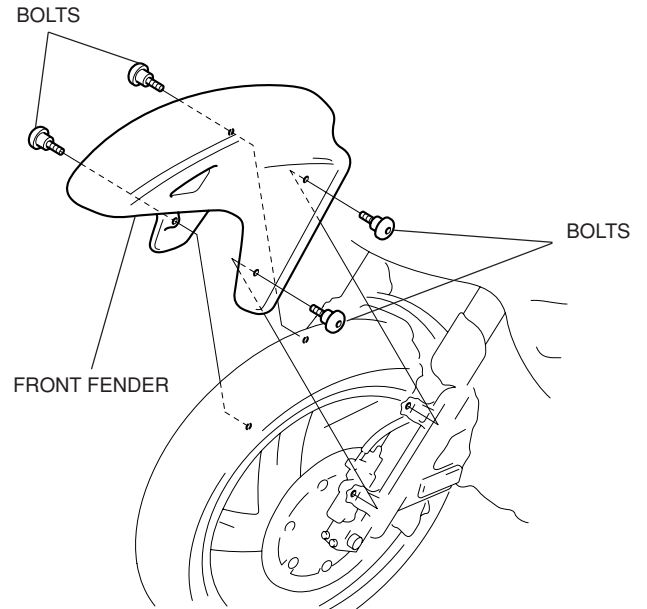

- Inside the front fender, locate the two marks on the right side and drill a hole through each mark using an electric drill motor starting with a 3,6,9, and 14 mm drill bit.

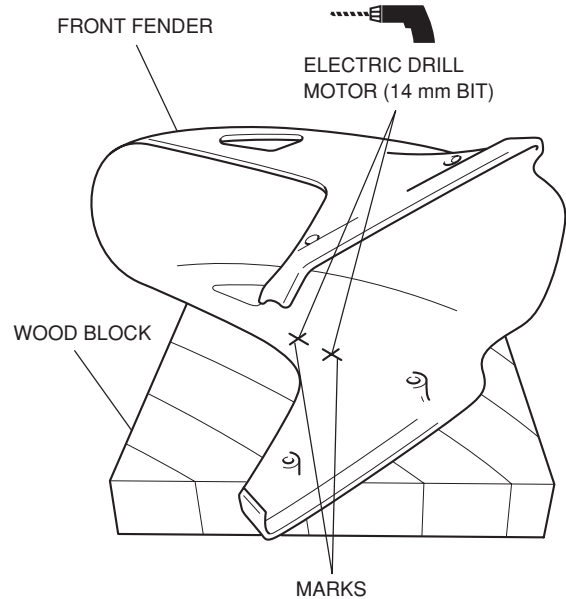

- Repeat on the left side.

4. Push a grommet into each of the four 14 mm holes made in steps 2 and 3.

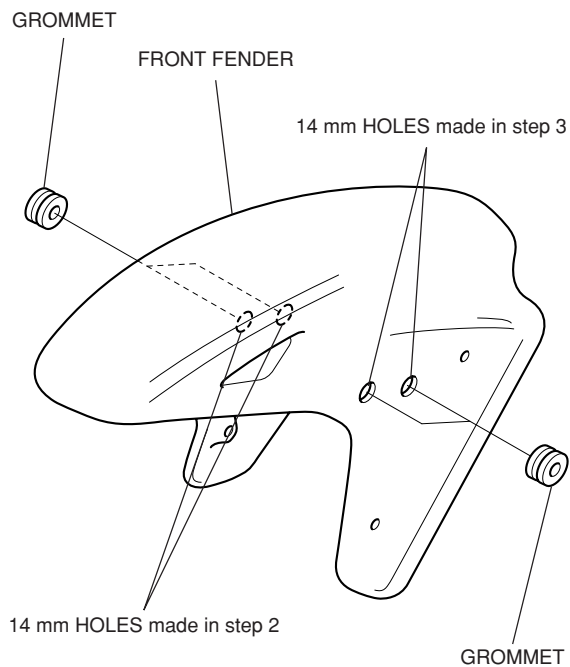

5. Remove the left front fork cover.

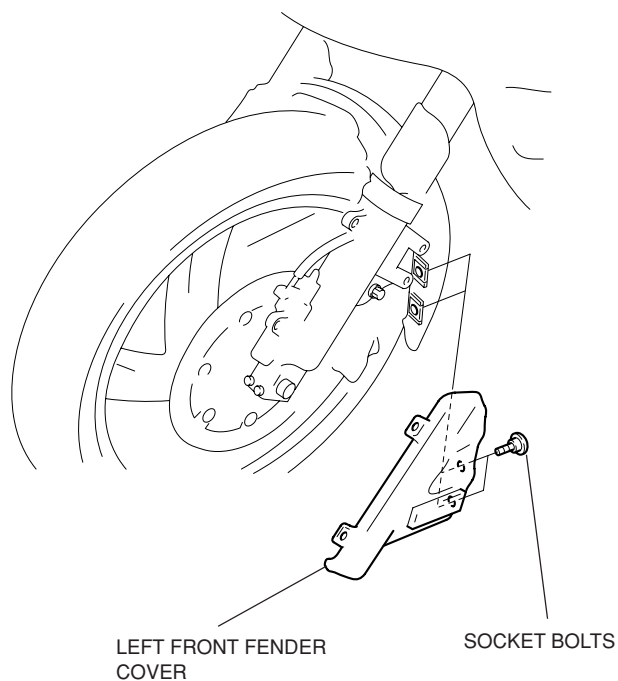

6. Remove the right front fork cover.

7. Install the left stay as shown.

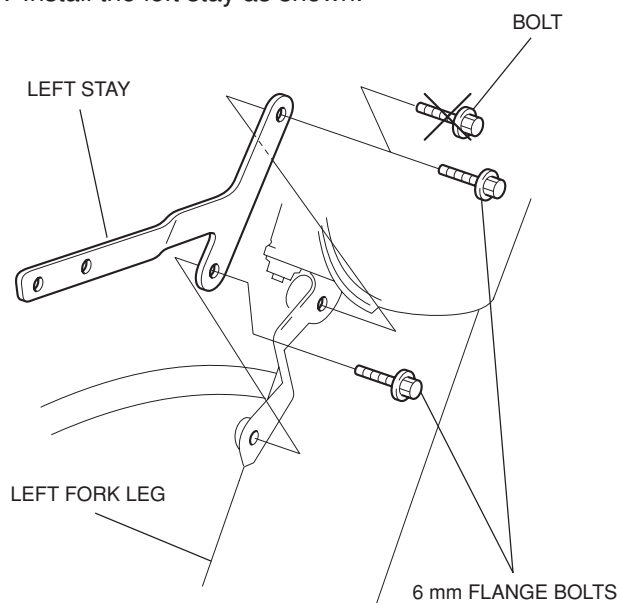

8. Install the right stay in the same manner as the left stay.
9. Reinstall the front fender covers in the reverse order of removal.
10. Temporarily install the front fender rail.

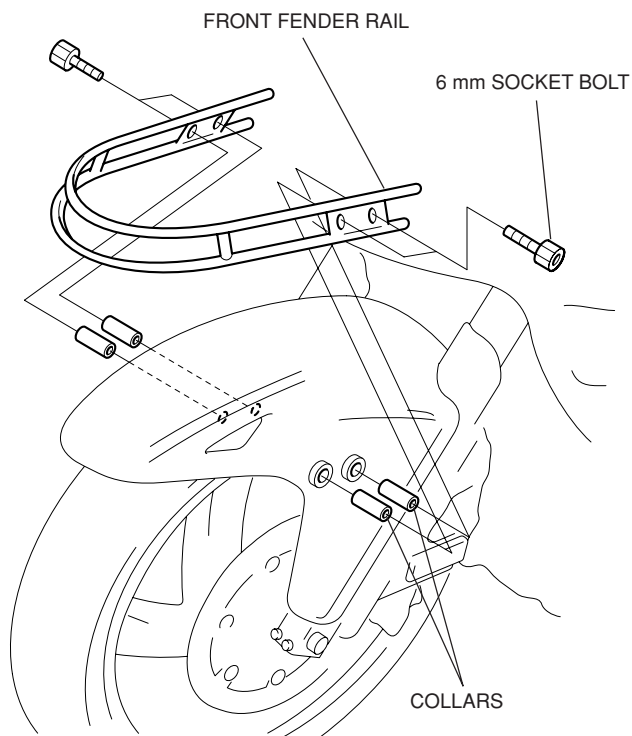

11. Tighten the 6 mm socket bolts loosely installed in the previous step.